

Order no.	Customer	Erection plan no.
804 306	KDE Sales and Service Inc.	804 306

Weight of machine	Weight kg	Floor area m ²	Total floor load load / floor kg/m ²	Supporting surface cm ²	Floor load Load /supp.surface kg/cm ²
Clamping unit (without options)	14000	3,40			
Injection unit – FIFO A: 5000cm ³	3200				
Demoulding table – 750mm stroke	450				
Subtotal clamping unit	17650	3,40	5191	66	267
Hydraulic unit (71cm ³ /U, 30kW) (incl. oil) and control cabinet	2200	3,00	733	12	183
Accessoires	-				
Total	19850	6,40			

Electrical data					
Motors total	kW 42	A 74,1	Heating total	kW 81,9	A 109,8
Power consumption	A 183,9		Primary fuse	A 200	
Power supply	3x 460V, Ground, 60Hz				²⁾ E
Recommended electrical cross-section of cable acc. to VDE 0298				mm ² 70	

Hydraulics - pneumatics - cooling water, consumptions and connections								
Tank volume Hydraulic oil	l	300	¹⁾ A	Tank volume Temperation oil	l	5x7	¹⁾ T	
Compressed air	bar	6	m ³ /h	0,5	Compressor capacity at 60 s cycle time	∅	9	²⁾ K
Cooling water	m ³ /h	2,2	Inlet temperature 20° C at 2,5 bar	Connection acc.to DIN 2353 - mm		22-L	²⁾ W	
Further data can be taken from erection plan and type plate at machine						E. & O. excepted		

Person i.c.	KE - M	Date	Person i.c.	KE - E	Date	Person i.c.	KE - H	Date
S.Denz		06.10.2005	K.Butsch		07.09.2005	R.Stefan		08.08.2005

1) Please see data sheet no. 0000.00.350.1

2) Please see erection plan as to location

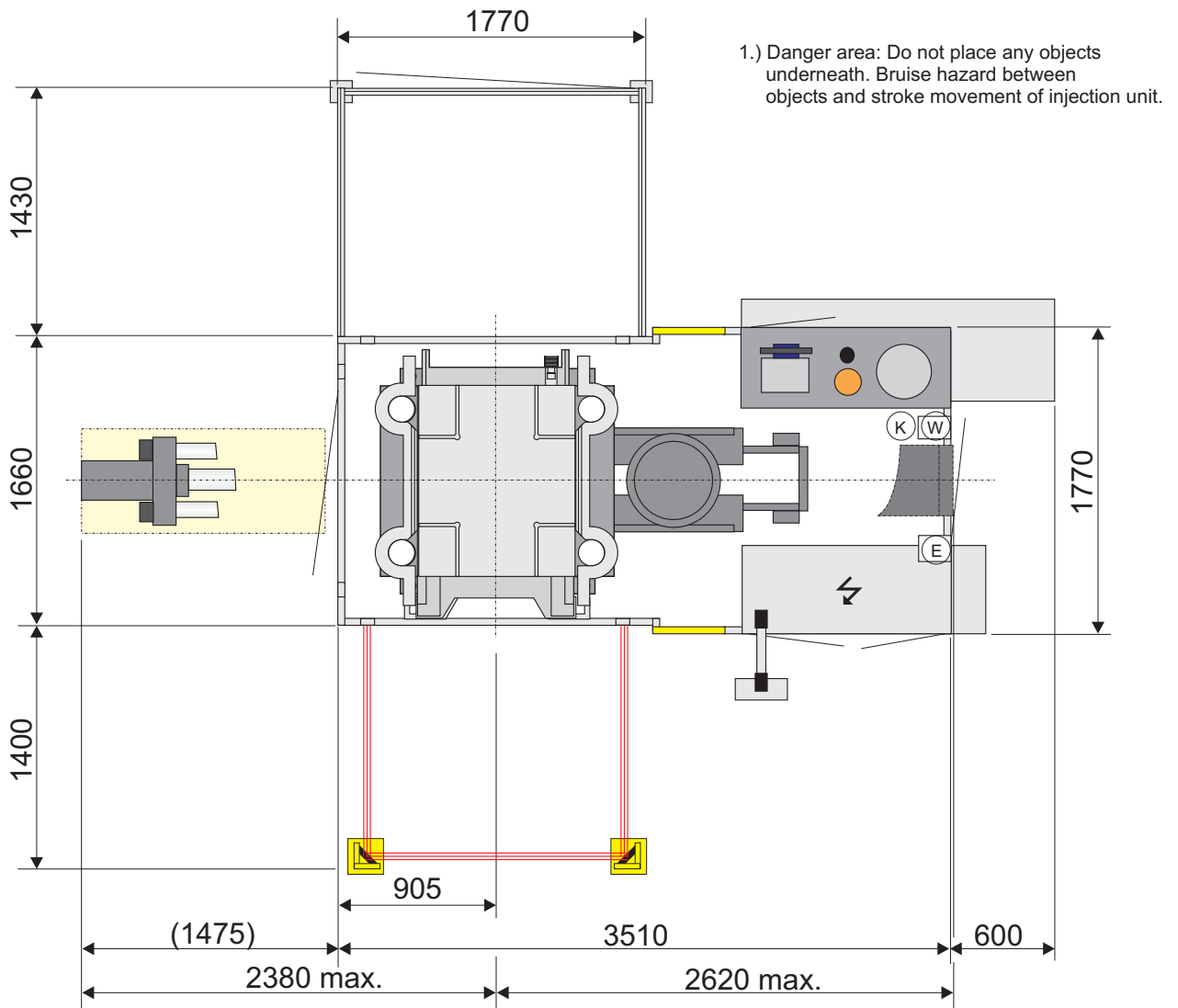
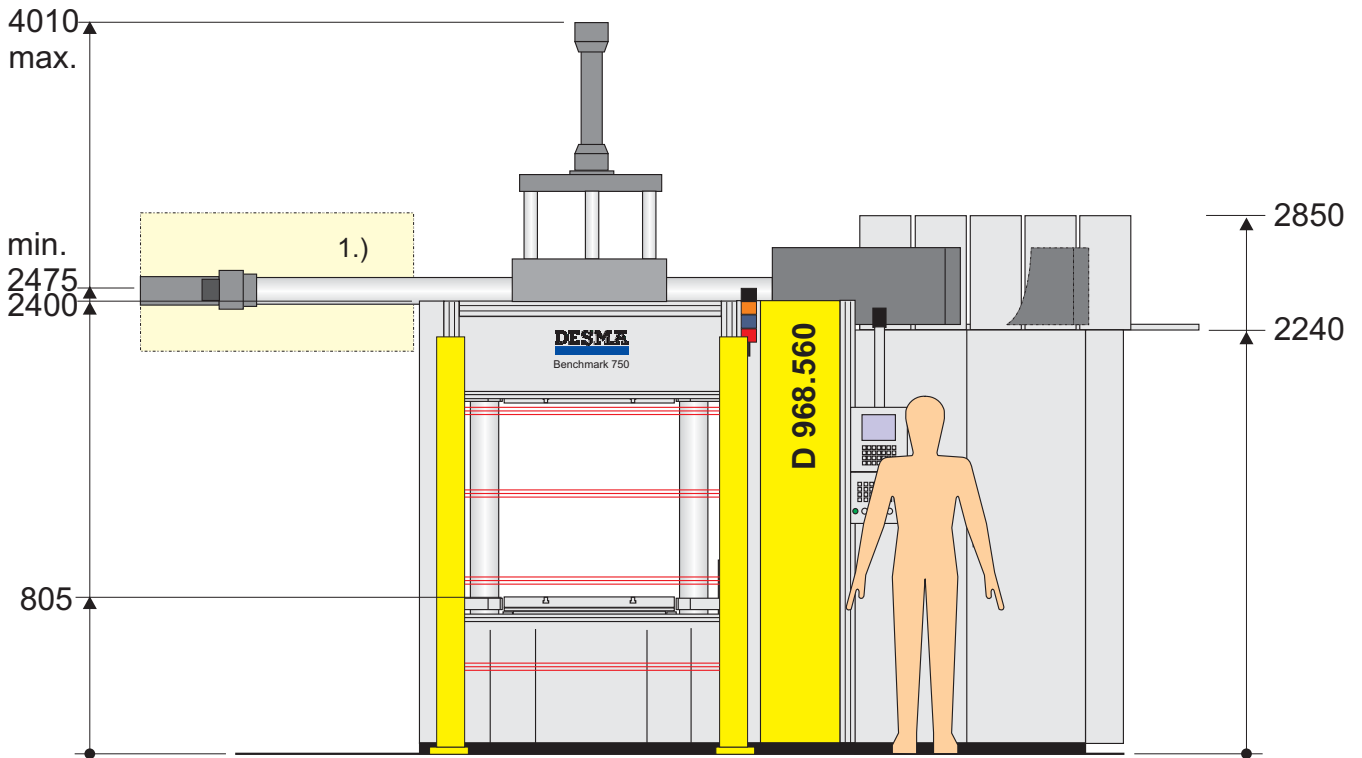

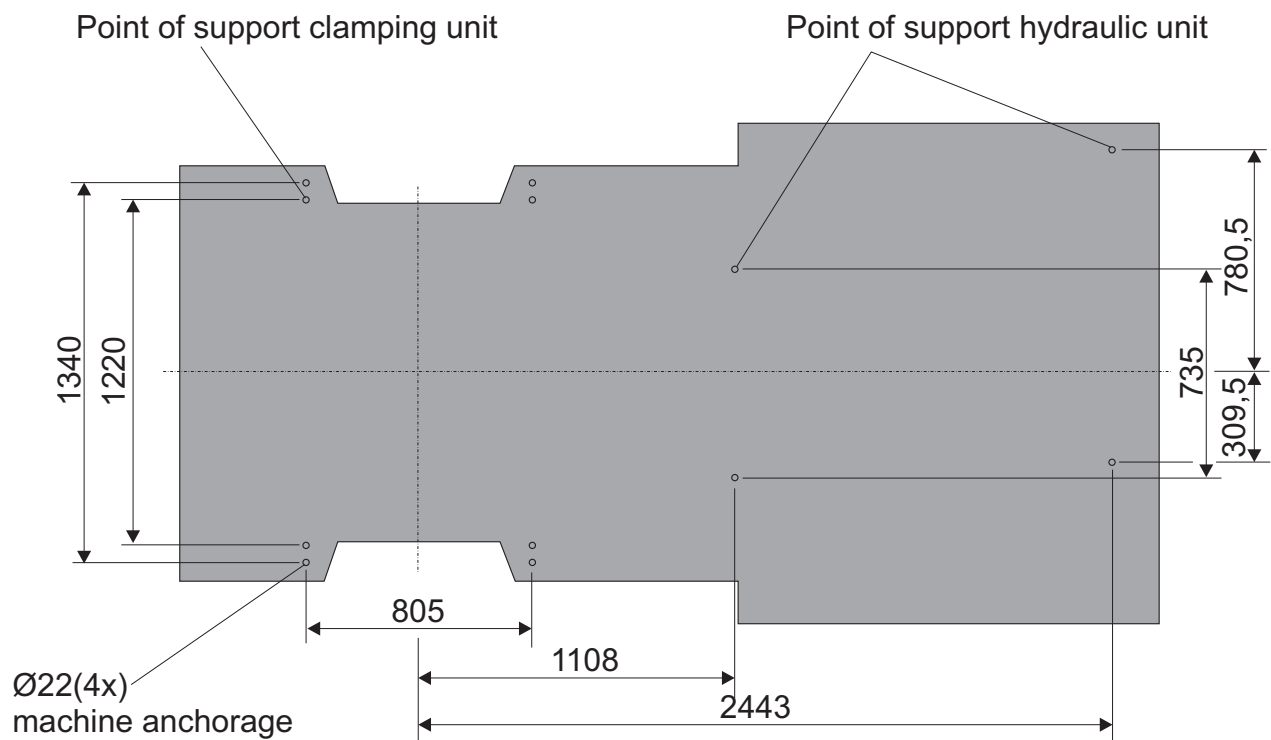

Machine needs to be anchored (805 x 1340 - M20 (4x)) with the foundation!
Fastening material (to anchor the machine) is not included in delivery.

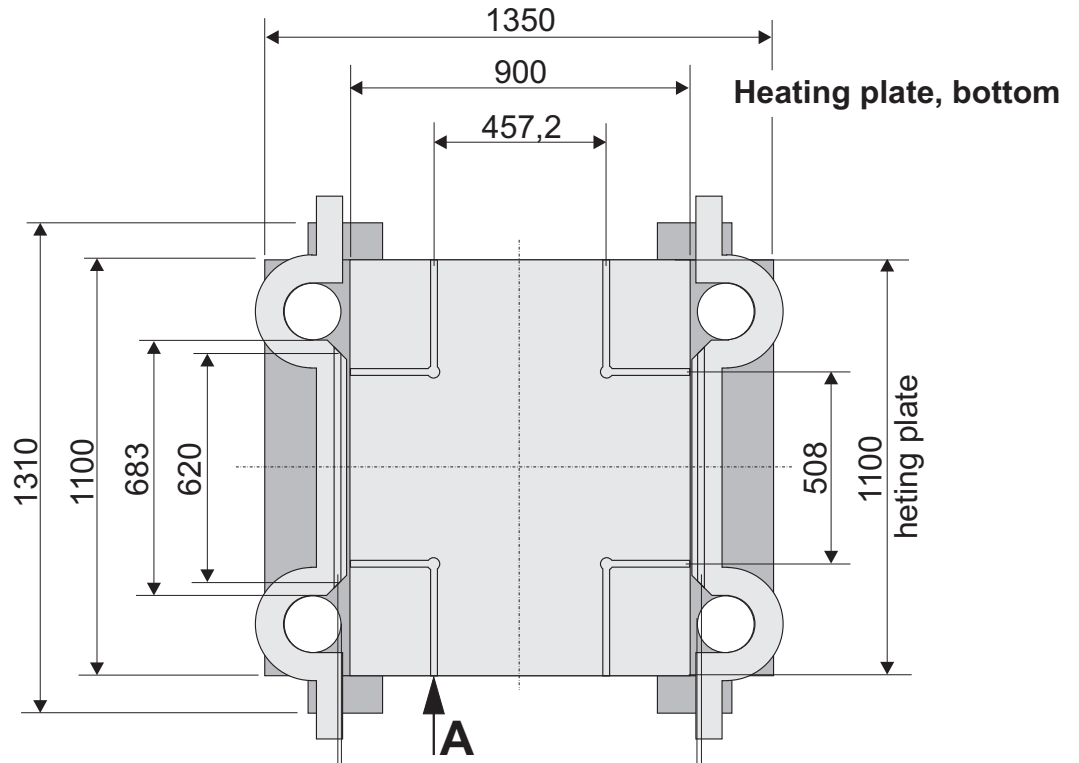

Detail A
DIN 650 (ISO 299)

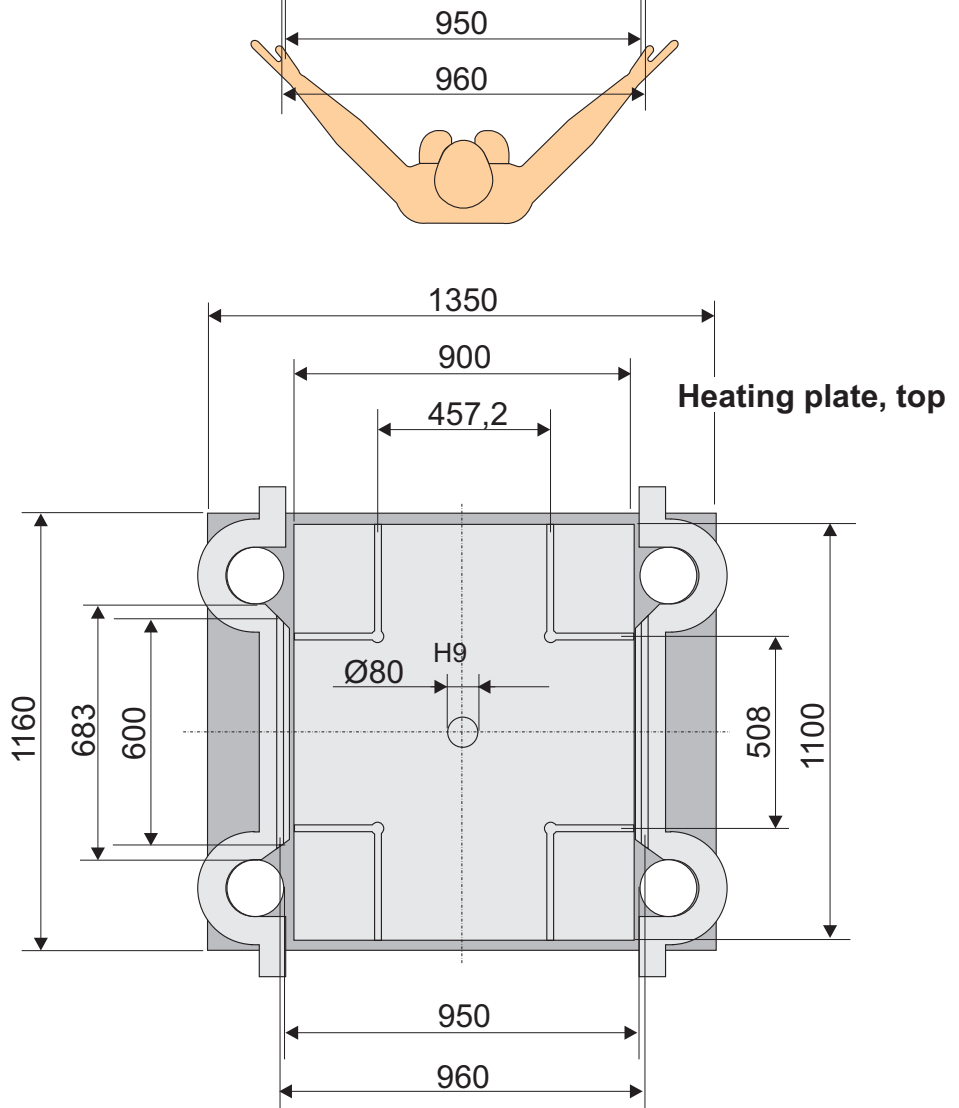
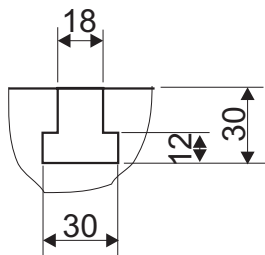

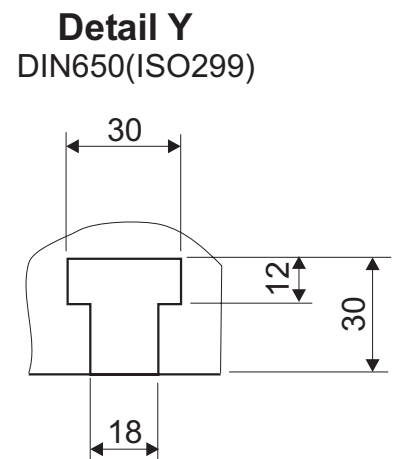
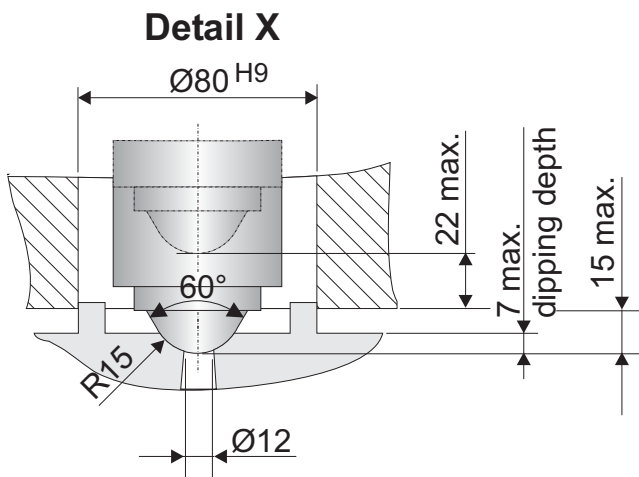
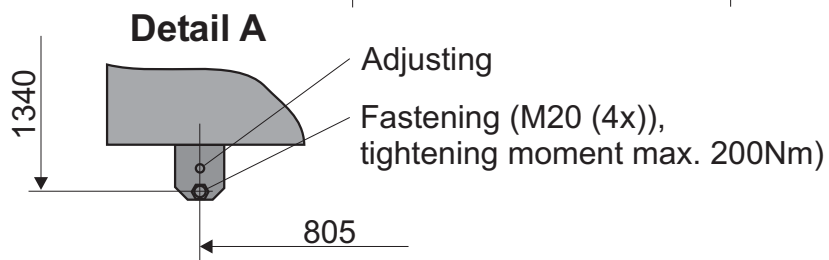
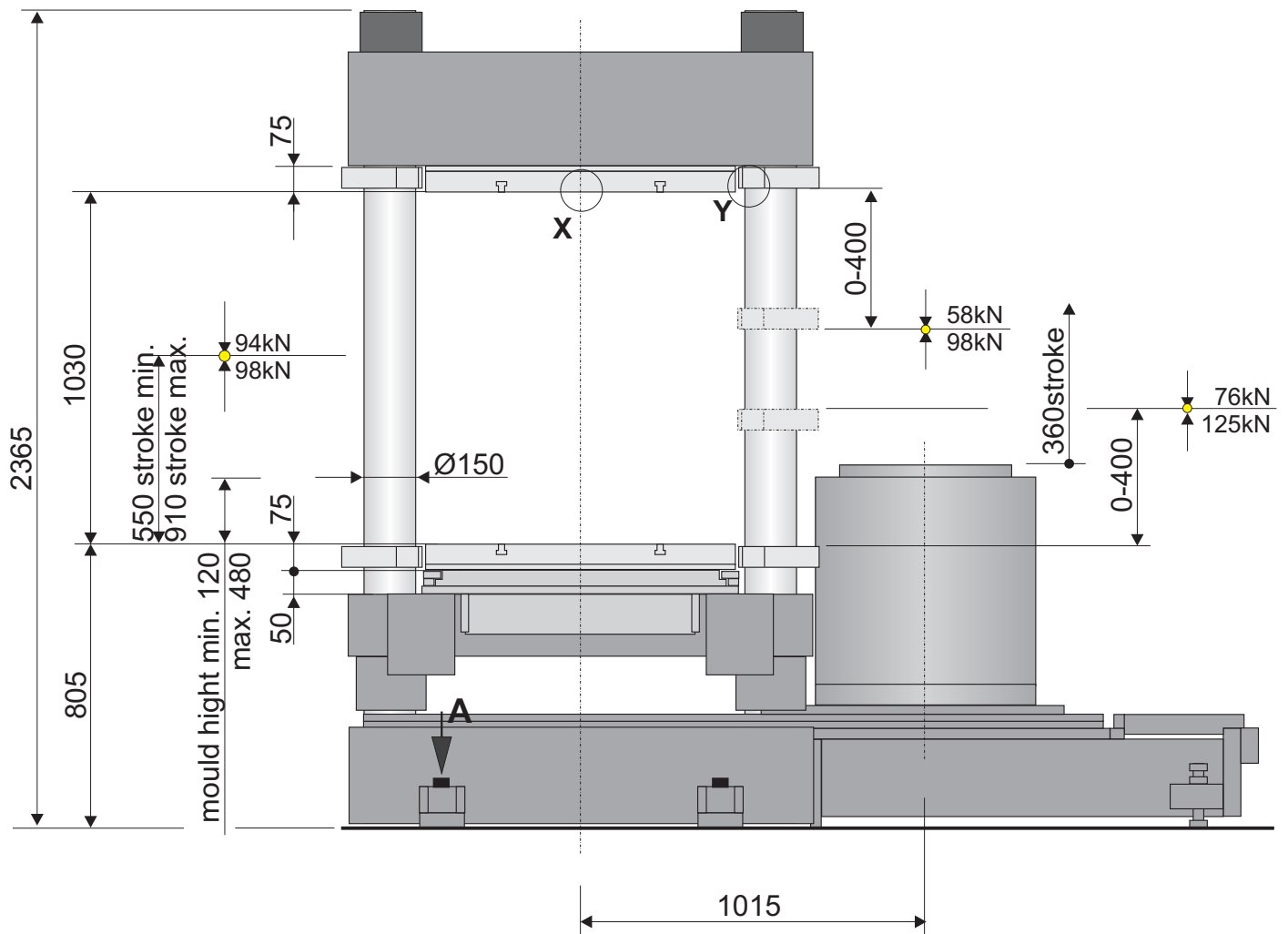

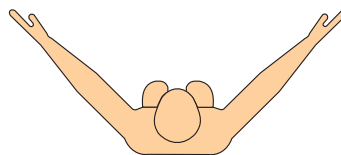
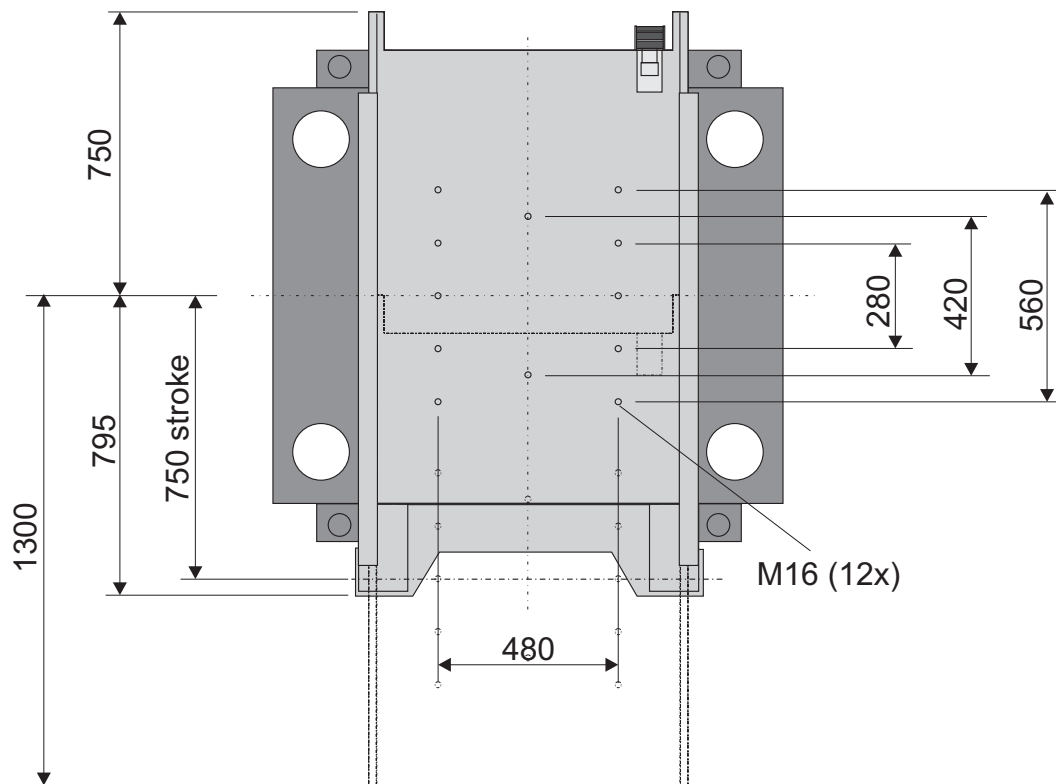
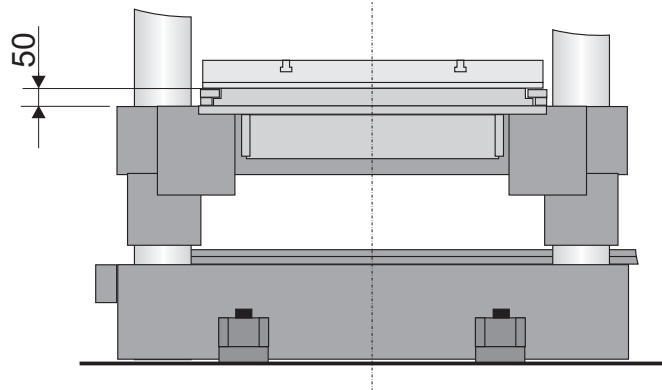

Permissible load demoulding table:
- mould change: 2000kg
- permanent operation: 1350kg

