

4000 - 10000
1740 bar, 6000cm³

805141
23.07.2008
WK

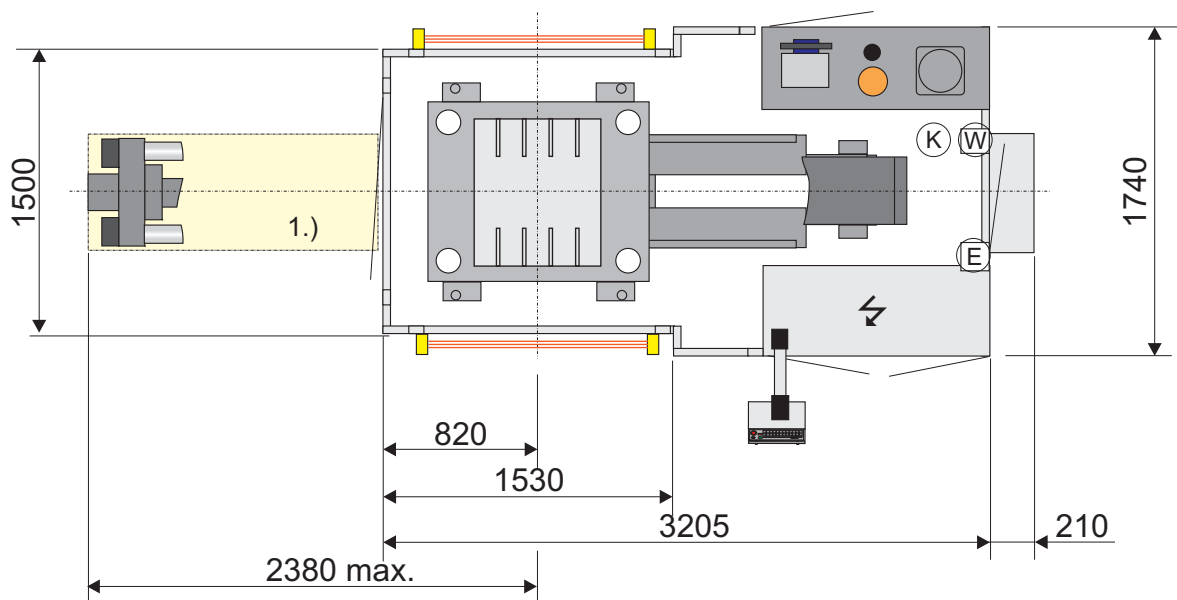

1.) Danger area: Do not place any objects underneath.
Bruise hazard between objects and stroke movement
of injection unit.

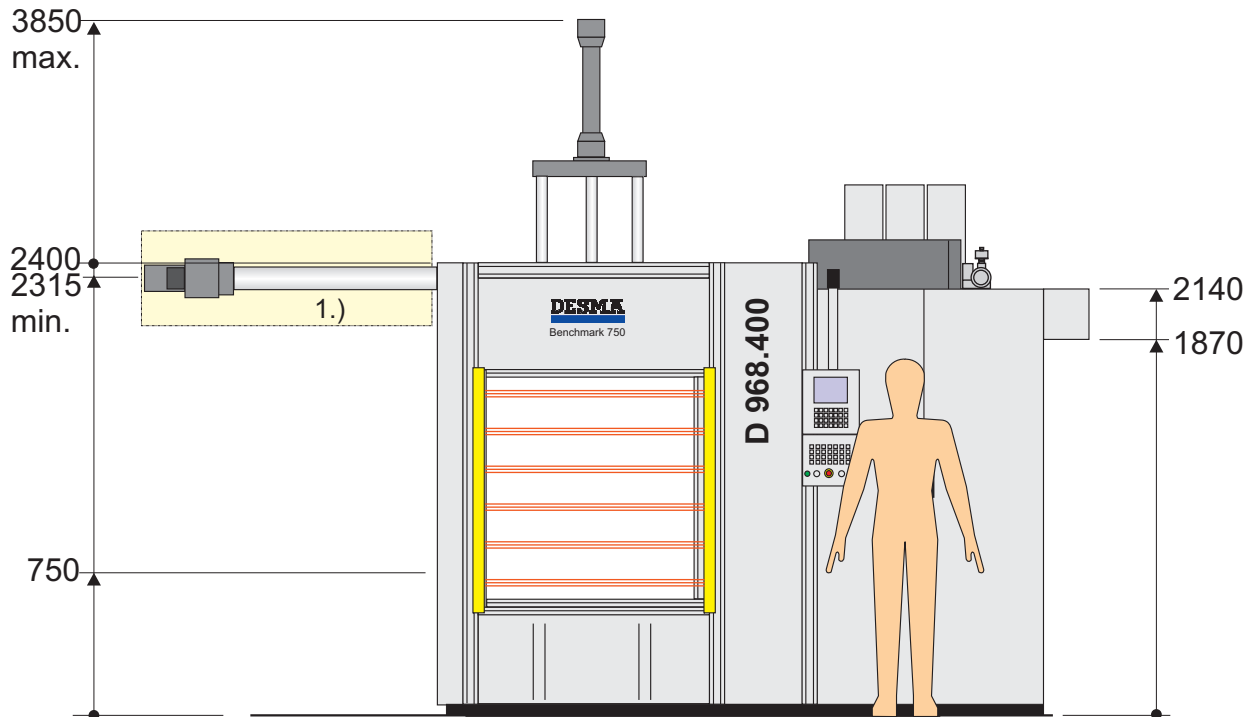
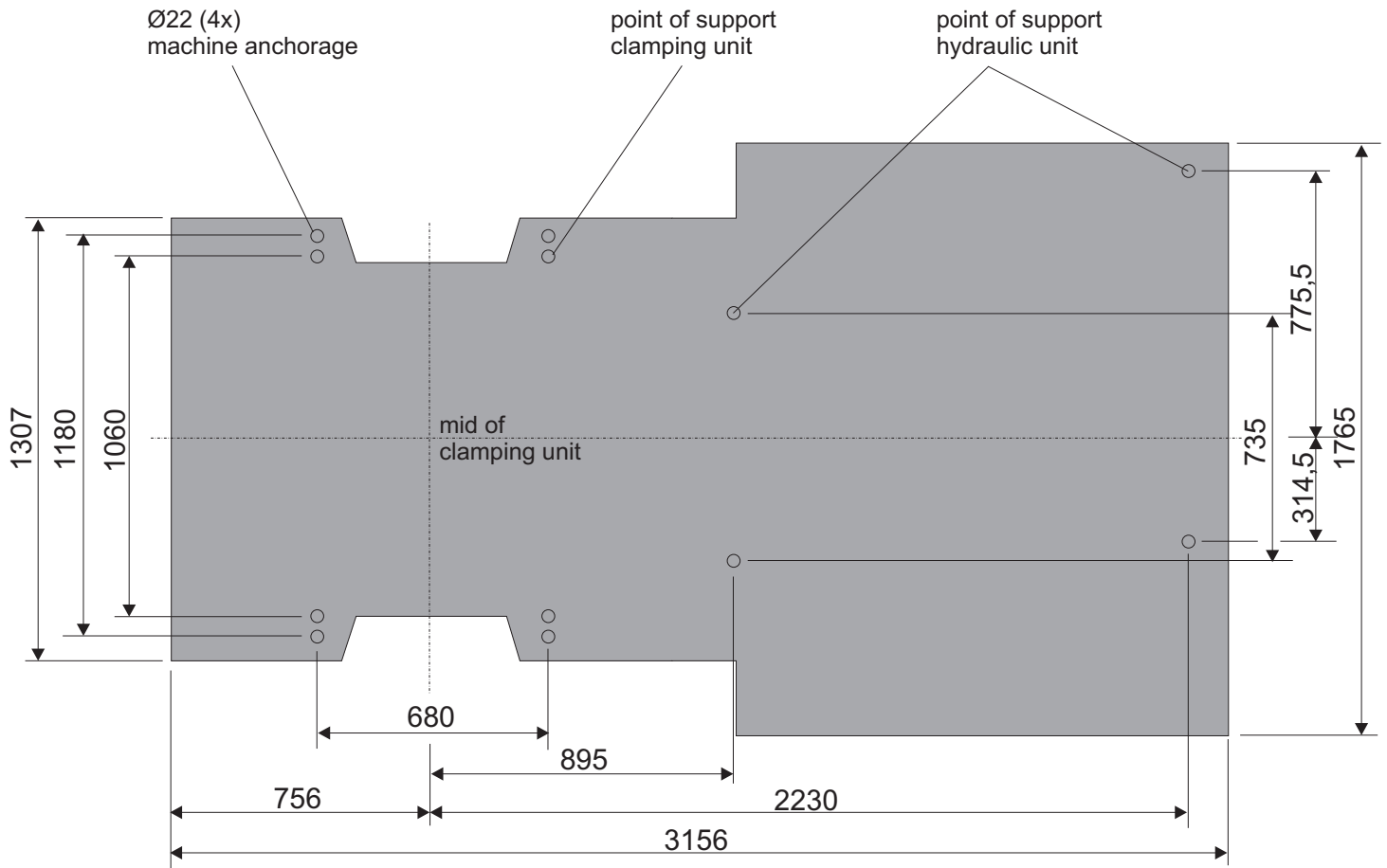

Machine needs to be anchored (680x1180 - M20 (4x)) with the foundation!
Fastening material (to anchor the machine) is not included in delivery

The heating platen and the core lifter bars are assembled by S&S.

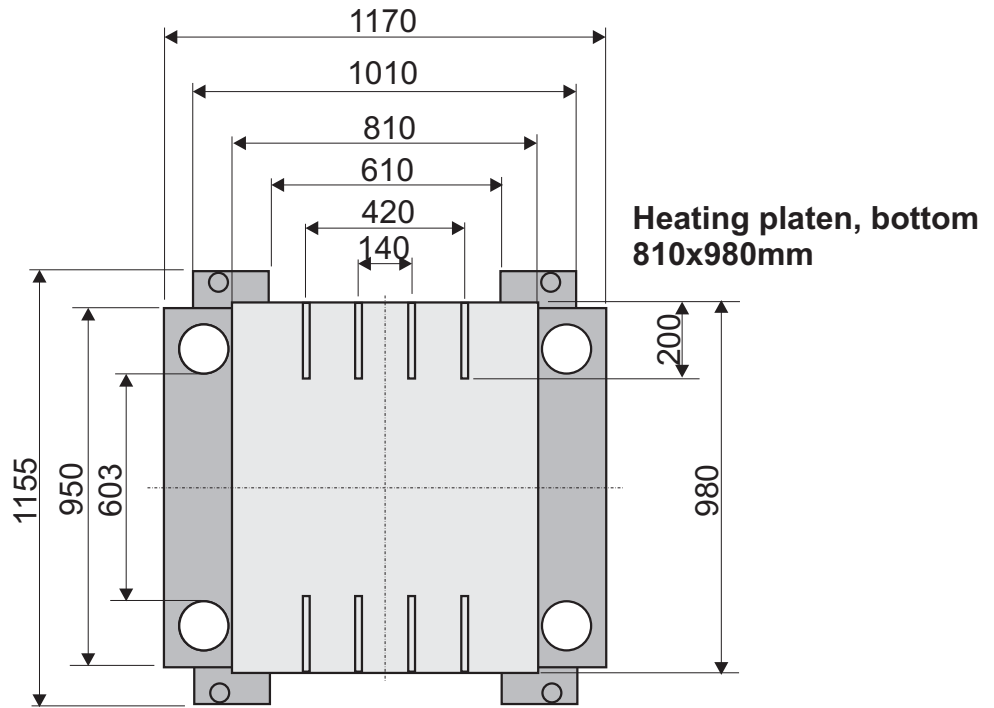

Detail A DIN650(ISO299)

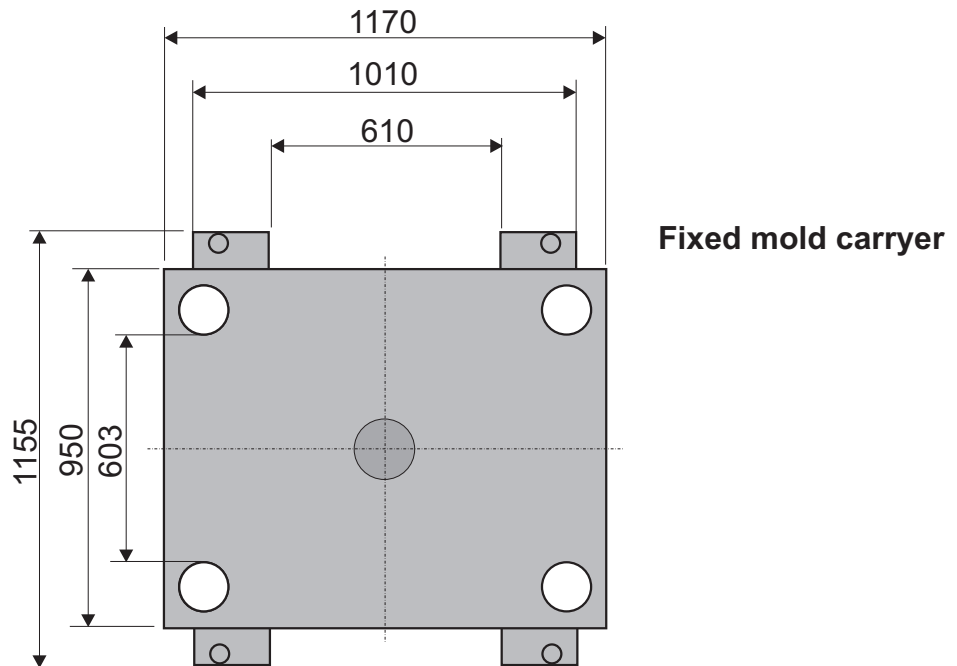
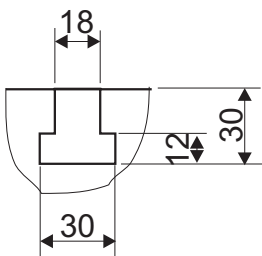

The heating platen and the core lifter bars are assembled by S&S.

