

US Units

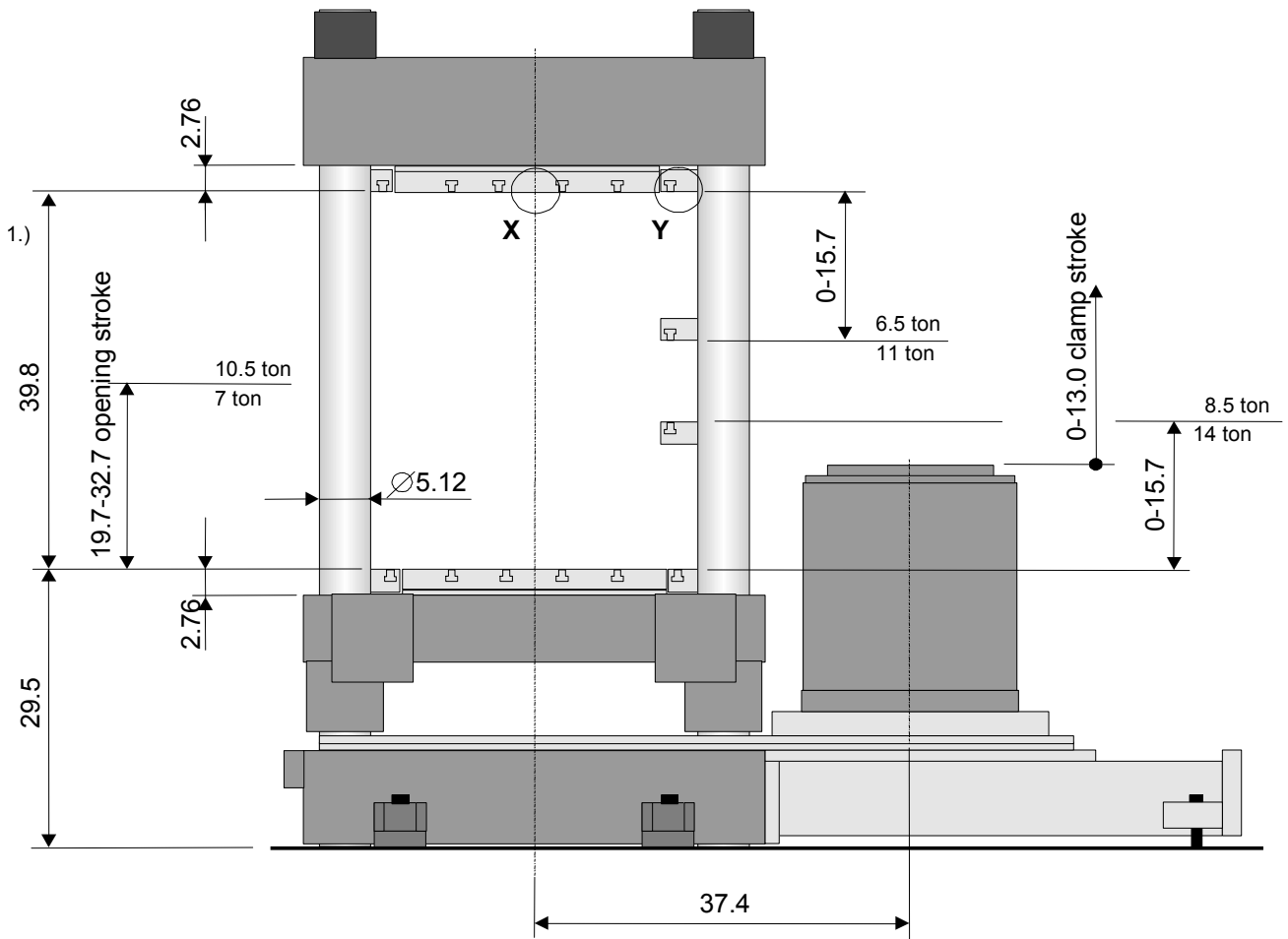

Detail X

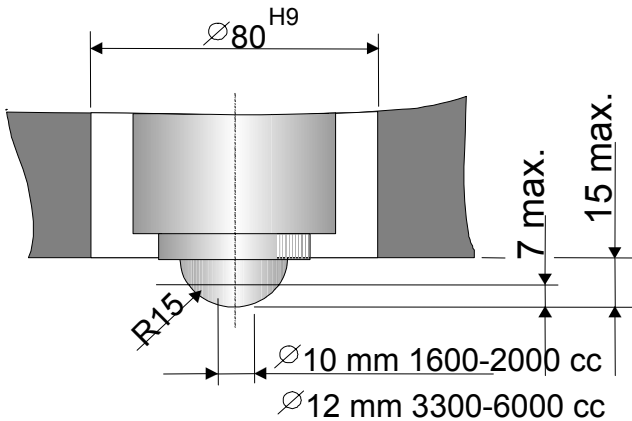

Detail Y

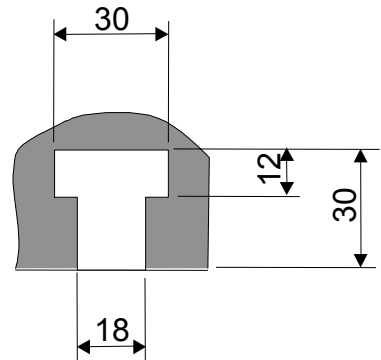

1.) standard available tie rod extensions
+150 / +300mm